

### Applications

- 1-4 cylinder diesel engines
- Power generation
- Construction equipment
- Agricultural equipment
- Electric motors
- Off road vehicles

### Benefits

- Excellent isolation for 1-4 cylinder engines
- Fail safe construction
- Multiple load ranges that overlap

### Load Range

- 1804 = 5 load ratings to 300 lbs.

### Attributes

- Rugged construction
- Easy to install
- Axial to radial stiffness of 6:1

### SNUBBING WASHERS

SERIES	P/N	O.D"	I.D"	THICKNESS"	MATERIAL	FINISH
1804	SW-2000-0450-0125-SW	2.00"	.450"	.125"	1010-1020 CRS	Clear Zinc

### Specifications

- Natural Frequency - 10-20 Hertz
- Transmissibility at resonance - 10:1
- Resilient Element - Neoprene
- Standard materials - Zinc plated steel
- Weight - 1804 = 7 oz.

### Elastomeric Data

- Neoprene elastomer has an operating temperature range of -40°F to +200°F (-40°C to +93°C) and is resistant to most solvents, oils and ozone.
- Other materials are available upon request.

Specifications subject to change without notice. Check with factory for latest revisions. The Federal Trade Commission considers no existing test methods or standards regarding flammability as accurate indicators of the performance of cellular plastic materials under actual fire conditions. Results of existing test methods, such as UL-94, MVSS-302, SAE J-369, and FAR 25.853 are intended only as measurements of the performance of such materials under specific controlled test conditions. Any flammability ratings shown are not intended to reflect hazards presented by these materials under actual fire conditions. The information contained herein is based on laboratory test data developed for PTI and is believed to be reliable, but its accuracy or completeness is not guaranteed. The buyer must test any product to determine the suitability for his specific application before use. PTI DISCLAIMS ANY RESPONSIBILITY FOR: 1) WARRANTIES OF FITNESS AND PURPOSE, 2) VERBAL RECOMMENDATIONS, 3) CONSEQUENTIAL DAMAGES FROM USE AND 4) VIOLATION OF ANY PATENTS OF TRADEMARKS HELD BY OTHERS.



Part #	Nominal Axial Load (lbs.)	Axial Stiffness at .10" Deflection (lbs./in.)	Transmissibility	Free Height (max. in.)	Resilient Materials	Structural Materials	Core Style	Center Hole	Flange Hole	Color Code
1804-1	50	500	10:1	1.25	Neoprene	Steel	Thru Hole	.396	.340	Red
1804-3	90	900	10:1	1.25	Neoprene	Steel	Thru Hole	.396	.340	Orange
1804-5	150	1500	10:1	1.25	Neoprene	Steel	Thru Hole	.396	.340	Yellow
1804-7	215	2150	10:1	1.25	Neoprene	Steel	Thru Hole	.396	.340	Green
1804-9	300	3000	10:1	1.25	Neoprene	Steel	Thru Hole	.396	.340	Blue

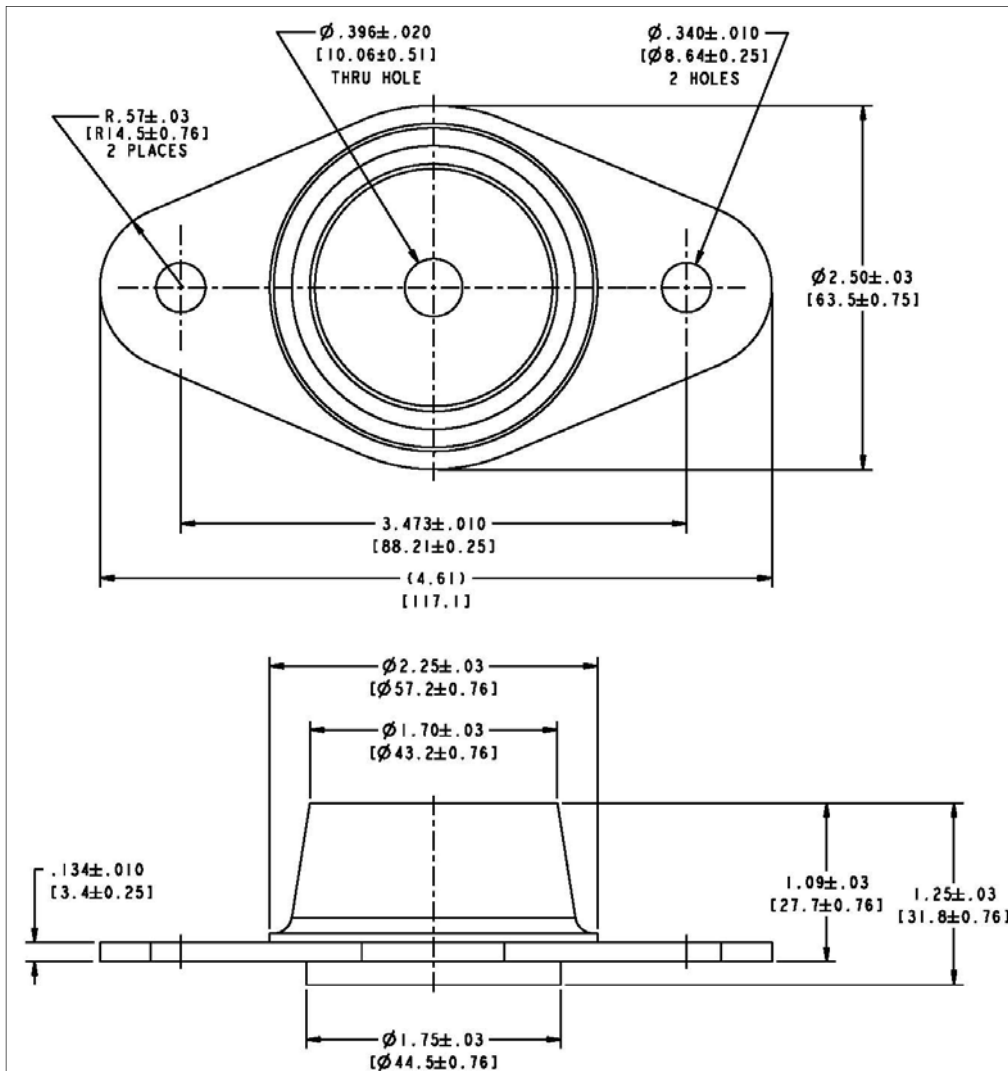

Specifications subject to change without notice. Check with factory for latest revisions. The Federal Trade Commission considers no existing test methods or standards regarding flammability as accurate indicators of the performance of cellular plastic materials under actual fire conditions. Results of existing test methods, such as UL-94, MVSS-302, SAE J-369, and FAR 25.853 are intended only as measurements of the performance of such materials under specific controlled test conditions. Any flammability ratings shown are not intended to reflect hazards presented by these materials under actual fire conditions. The information contained herein is based on laboratory test data developed for PTI and is believed to be reliable, but its accuracy or completeness is not guaranteed. The buyer must test any product to determine the suitability for his specific application before use. PTI DISCLAIMS ANY RESPONSIBILITY FOR: 1) WARRANTIES OF FITNESS AND PURPOSE, 2) VERBAL RECOMMENDATIONS, 3) CONSEQUENTIAL DAMAGES FROM USE AND 4) VIOLATION OF ANY PATENTS OR TRADEMARKS HELD BY OTHERS.

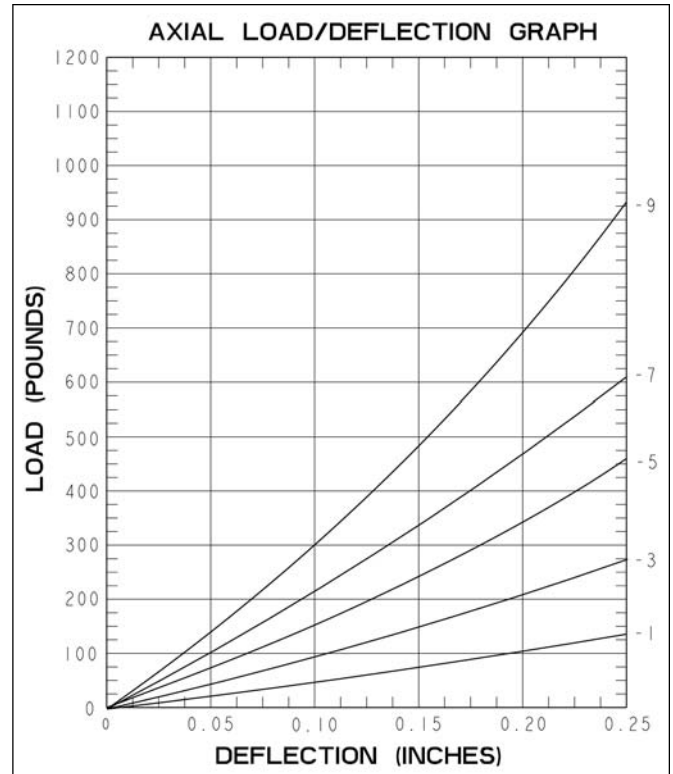
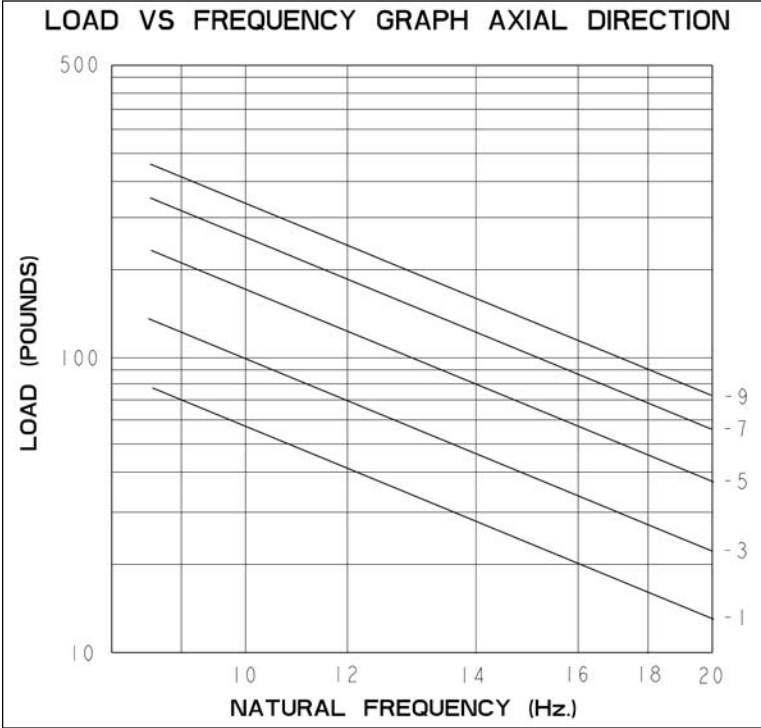

Specifications subject to change without notice. Check with factory for latest revisions. The Federal Trade Commission considers no existing test methods or standards regarding flammability as accurate indicators of the performance of cellular plastic materials under actual fire conditions. Results of existing test methods, such as UL-94, MVSS-302, SAE J-369, and FAR 25.853 are intended only as measurements of the performance of such materials under specific controlled test conditions. Any flammability ratings shown are not intended to reflect hazards presented by these materials under actual fire conditions. The information contained herein is based on laboratory test data developed for PTI and is believed to be reliable, but its accuracy or completeness is not guaranteed. The buyer must test any product to determine the suitability for his specific application before use. PTI DISCLAIMS ANY RESPONSIBILITY FOR: 1) WARRANTIES OF FITNESS AND PURPOSE, 2) VERBAL RECOMMENDATIONS, 3) CONSEQUENTIAL DAMAGES FROM USE AND 4) VIOLATION OF ANY PATENTS OR TRADEMARKS HELD BY OTHERS.