

Applications

- Pumps
- Electric motors
- Fans & blowers
- HVAC
- Communications equipment
- Business machines
- Electronics

Load Range

- 1815/1816 = 4 load ratings to 12 lbs. max.
- 1818/1819 = 4 load ratings to 35 lbs. max.
- 1821/1822 = 4 load ratings to 75 lbs. max.
- 1826/1827 = 4 load ratings to 350 lbs. max.

Attributes

- Available in four sizes
- Low-cost but effective isolation
- Ribbed design aids in isolation
- Can be installed in parallel or series for greater load capacity or deflection

Specifications

- Natural Frequency—See tables
- Transmissibility at resonance—10:1
- Resilient Element—Natural Rubber
- Standard materials—None
- Weight—1826 = 3.37 oz. (all other parts weigh less than 1.0 oz.)

Elastomeric Data

- Natural Rubber elastomer is compatible with most industrial and commercial environments and has an operating temperature range of -25°F to $+160^{\circ}\text{F}$ (-37°C to $+70^{\circ}\text{C}$). Special materials are available upon special order.

Specifications subject to change without notice. Check with factory for latest revisions. The Federal Trade Commission considers no existing test methods or standards regarding flammability as accurate indicators of the performance of cellular plastic materials under actual fire conditions. Results of existing test methods, such as UL-94, MVSS-302, SAE J-369, and FAR 25.853 are intended only as measurements of the performance of such materials under specific controlled test conditions. Any flammability ratings shown are not intended to reflect hazards presented by these materials under actual fire conditions. The information contained herein is based on laboratory test data developed for PTI and is believed to be reliable, but its accuracy or completeness is not guaranteed. The buyer must test any product to determine the suitability for his specific application before use. PTI DISCLAIMS ANY RESPONSIBILITY FOR: 1) WARRANTIES OF FITNESS AND PURPOSE, 2) VERBAL RECOMMENDATIONS, 3) CONSEQUENTIAL DAMAGES FROM USE AND 4) VIOLATION OF ANY PATENTS OF TRADEMARKS HELD BY OTHERS.



RECOMMENDED LOAD LIMITS FOR RING & BUSHING ASSEMBLY					
Part #	Size	Minimum Load (lbs.)	Max. Load (lbs.)	Standard Material / Durometer	FN at max load
1826/1827 -1	6	60	120	Neoprene 30	7
1826/1827 -2	6	110	160	Neoprene 40	7
1826/1827 -3	6	135	250	Neoprene 50	7.5
1826/1827 -4	6	160	350	Neoprene 60	8

1826 (Bushing)

Dimensional tolerance ±.03"

1827 (Ring)

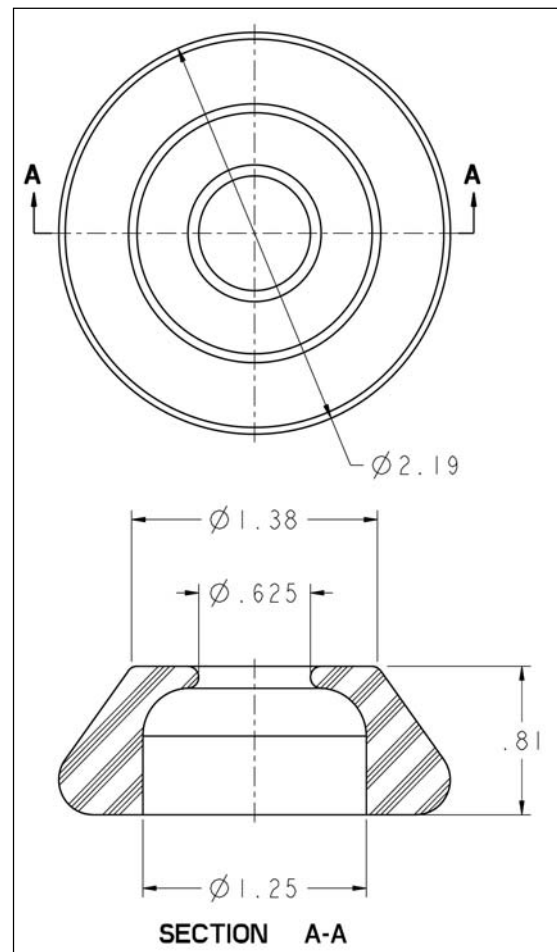
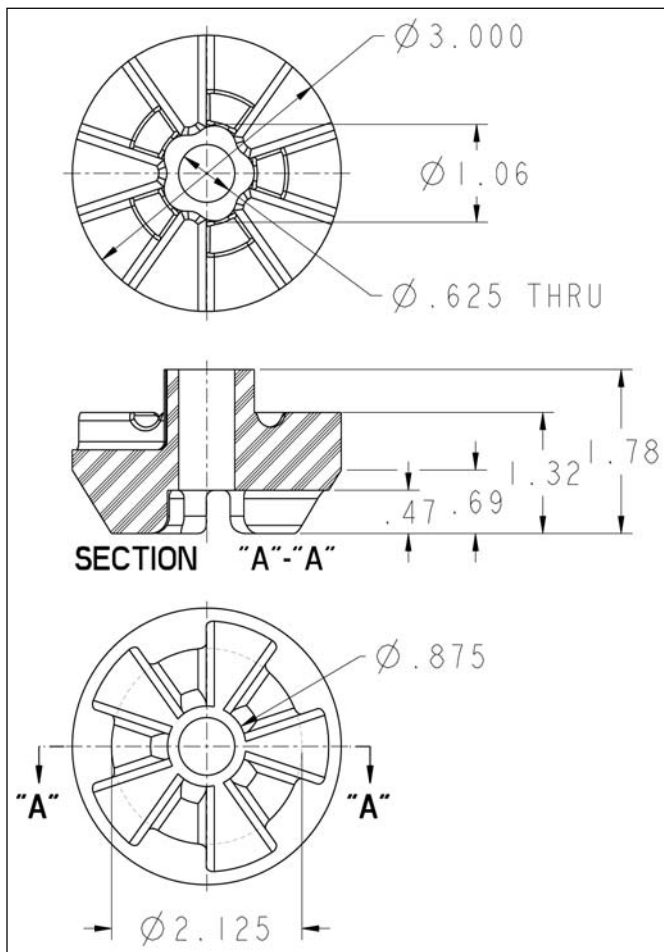

Specifications subject to change without notice. Check with factory for latest revisions. The Federal Trade Commission considers no existing test methods or standards regarding flammability as accurate indicators of the performance of cellular plastic materials under actual fire conditions. Results of existing test methods, such as UL-94, MVSS-302, SAE J-369, and FAR 25.853 are intended only as measurements of the performance of such materials under specific controlled test conditions. Any flammability ratings shown are not intended to reflect hazards presented by these materials under actual fire conditions. The information contained herein is based on laboratory test data developed for PTI and is believed to be reliable, but its accuracy or completeness is not guaranteed. The buyer must test any product to determine the suitability for his specific application before use. PTI DISCLAIMS ANY RESPONSIBILITY FOR: 1) WARRANTIES OF FITNESS AND PURPOSE, 2) VERBAL RECOMMENDATIONS, 3) CONSEQUENTIAL DAMAGES FROM USE AND 4) VIOLATION OF ANY PATENTS OF TRADEMARKS HELD BY OTHERS.