



Attributes

- Silicone gel produces a high level of damping
- Axial to radial stiffness ratio 1:1
- Compact, low profile design
- Easy to install
- Silicone elastomer
- Stainless steel construction
- Designed for severe ground vehicle vibration inputs
- Outstanding dynamic fatigue life
- Fail Safe with ground strap

Applications

- Military ground vehicle COTS electronics (Mil-810)
- Military wheeled and tracked vehicle applications
- Airborne electronics (Mil-810)
- Shock and vibration applications where a high level of damping is required

Load Range

- Load ratings are 11-17 lbs.
- Can be custom tailored to specific applications

Elastomeric Data

- Silicone has an operating temperature range of -67°F to $+300^{\circ}\text{F}$ (-55°C to $+150^{\circ}\text{C}$)
- Resistant to fungus, most solvents and ozone
- Other elastomeric formulations are available in Neoprene

Specifications subject to change without notice. Check with factory for latest revisions. The Federal Trade Commission considers no existing test methods or standards regarding flammability as accurate indicators of the performance of cellular plastic materials under actual fire conditions. Results of existing test methods, such as UL-94, MVSS-302, SAE J-369, and FAR 25.853 are intended only as measurements of the performance of such materials under specific controlled test conditions. Any flammability ratings shown are not intended to reflect hazards presented by these materials under actual fire conditions. The information contained herein is based on laboratory test data developed for PTI and is believed to be reliable, but its accuracy or completeness is not guaranteed. The buyer must test any product to determine the suitability for his specific application before use. PTI DISCLAIMS ANY RESPONSIBILITY FOR: 1) WARRANTIES OF FITNESS AND PURPOSE, 2) VERBAL RECOMMENDATIONS, 3) CONSEQUENTIAL DAMAGES FROM USE AND 4) VIOLATION OF ANY PATENTS OF TRADEMARKS HELD BY OTHERS.



Part #	Load Range Vehicular (lbs.)	Load Range Airborne (lbs.)	Axial Natural Frequency (hz)	Standard Material	Standard Elastomer	Transmissibility at Resonance Max.
1962-00	11-17	11-17	6-10	304 SS	Silicone/Silicone Gel	2.5:1

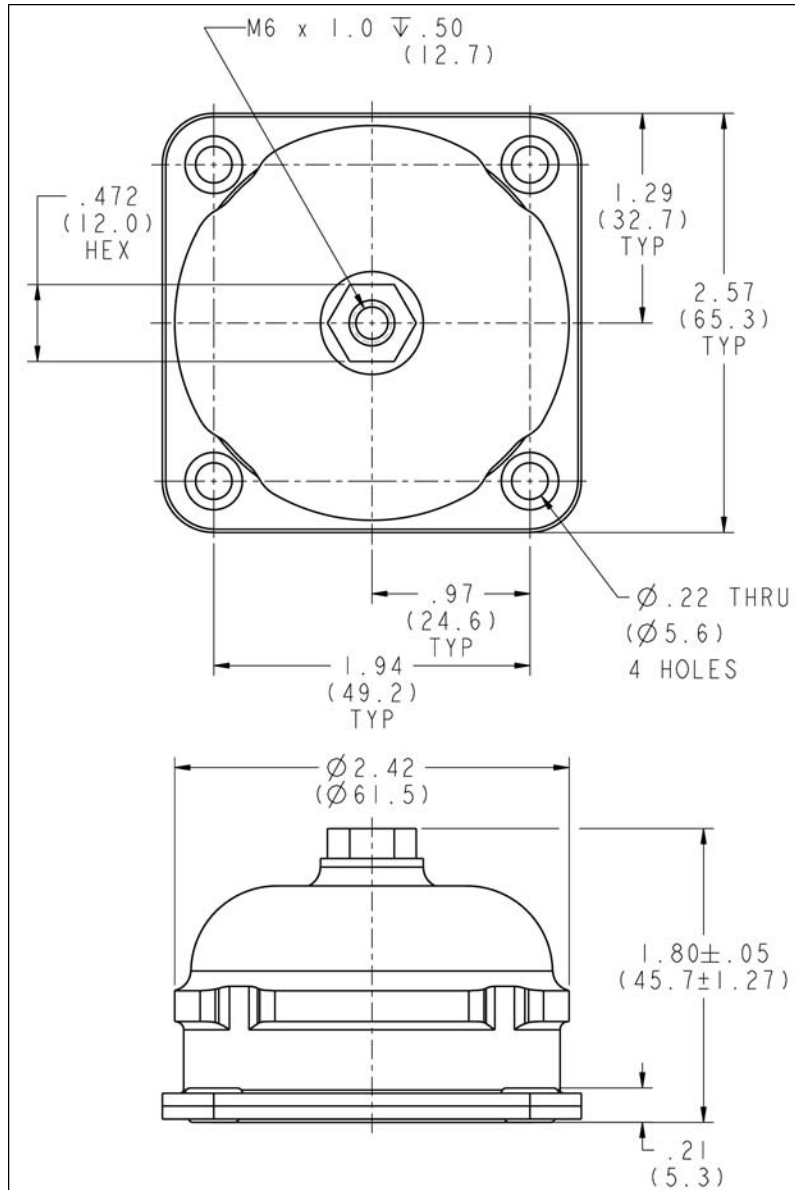

Specifications subject to change without notice. Check with factory for latest revisions. The Federal Trade Commission considers no existing test methods or standards regarding flammability as accurate indicators of the performance of cellular plastic materials under actual fire conditions. Results of existing test methods, such as UL-94, MVSS-302, SAE J-369, and FAR 25.853 are intended only as measurements of the performance of such materials under specific controlled test conditions. Any flammability ratings shown are not intended to reflect hazards presented by these materials under actual fire conditions. The information contained herein is based on laboratory test data developed for PTI and is believed to be reliable, but its accuracy or completeness is not guaranteed. The buyer must test any product to determine the suitability for his specific application before use. PTI DISCLAIMS ANY RESPONSIBILITY FOR: 1) WARRANTIES OF FITNESS AND PURPOSE, 2) VERBAL RECOMMENDATIONS, 3) CONSEQUENTIAL DAMAGES FROM USE AND 4) VIOLATION OF ANY PATENTS OF TRADEMARKS HELD BY OTHERS.

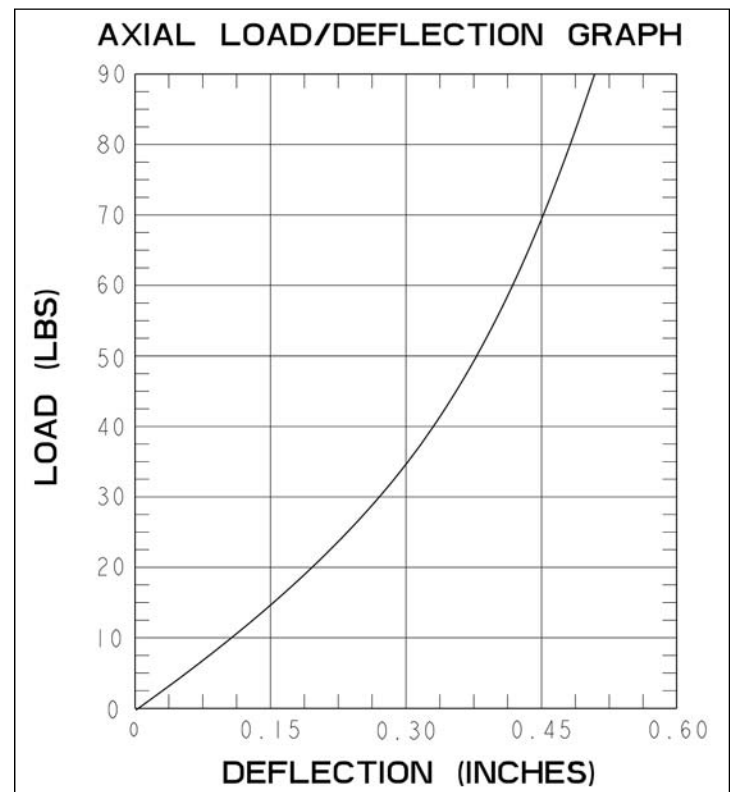
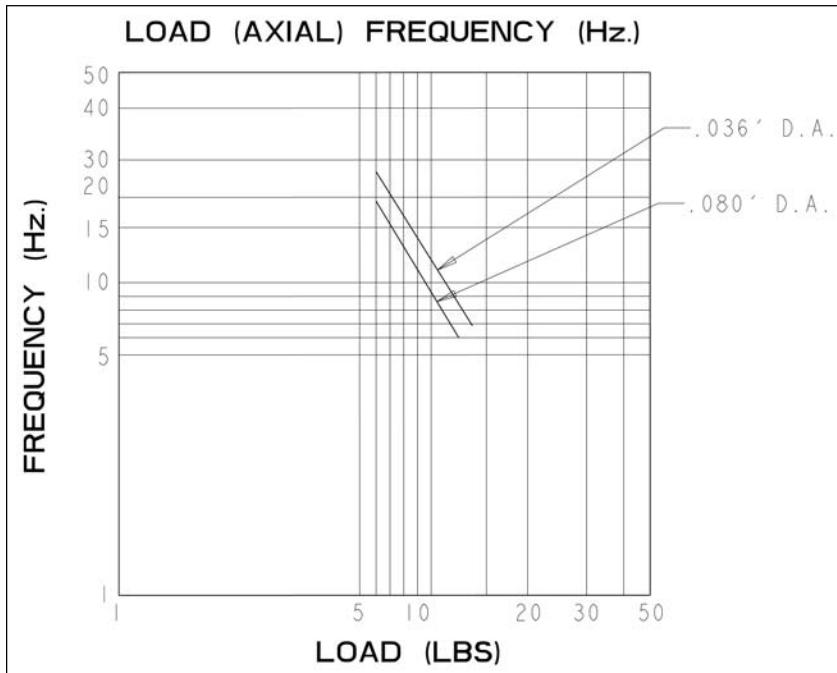

Specifications subject to change without notice. Check with factory for latest revisions. The Federal Trade Commission considers no existing test methods or standards regarding flammability as accurate indicators of the performance of cellular plastic materials under actual fire conditions. Results of existing test methods, such as UL-94, MVSS-302, SAE J-369, and FAR 25.853 are intended only as measurements of the performance of such materials under specific controlled test conditions. Any flammability ratings shown are not intended to reflect hazards presented by these materials under actual fire conditions. The information contained herein is based on laboratory test data developed for PTI and is believed to be reliable, but its accuracy or completeness is not guaranteed. The buyer must test any product to determine the suitability for his specific application before use. PTI DISCLAIMS ANY RESPONSIBILITY FOR: 1) WARRANTIES OF FITNESS AND PURPOSE, 2) VERBAL RECOMMENDATIONS, 3) CONSEQUENTIAL DAMAGES FROM USE AND 4) VIOLATION OF ANY PATENTS OR TRADEMARKS HELD BY OTHERS.